

Best Practices for Supporting Models

Printing

Do not heat the resin.

Due to the wax content in the resin, please ensure you shake the bottle very well before you pour the resin into your VAT.

Before each print, thoroughly stir the resin sitting in the VAT to ensure the material is well mixed before the print.

Avoid printing flat objects directly to the build plate as the high wax content of the resin will make part removal difficult. As per Image (img 1.1)

Img 1.1

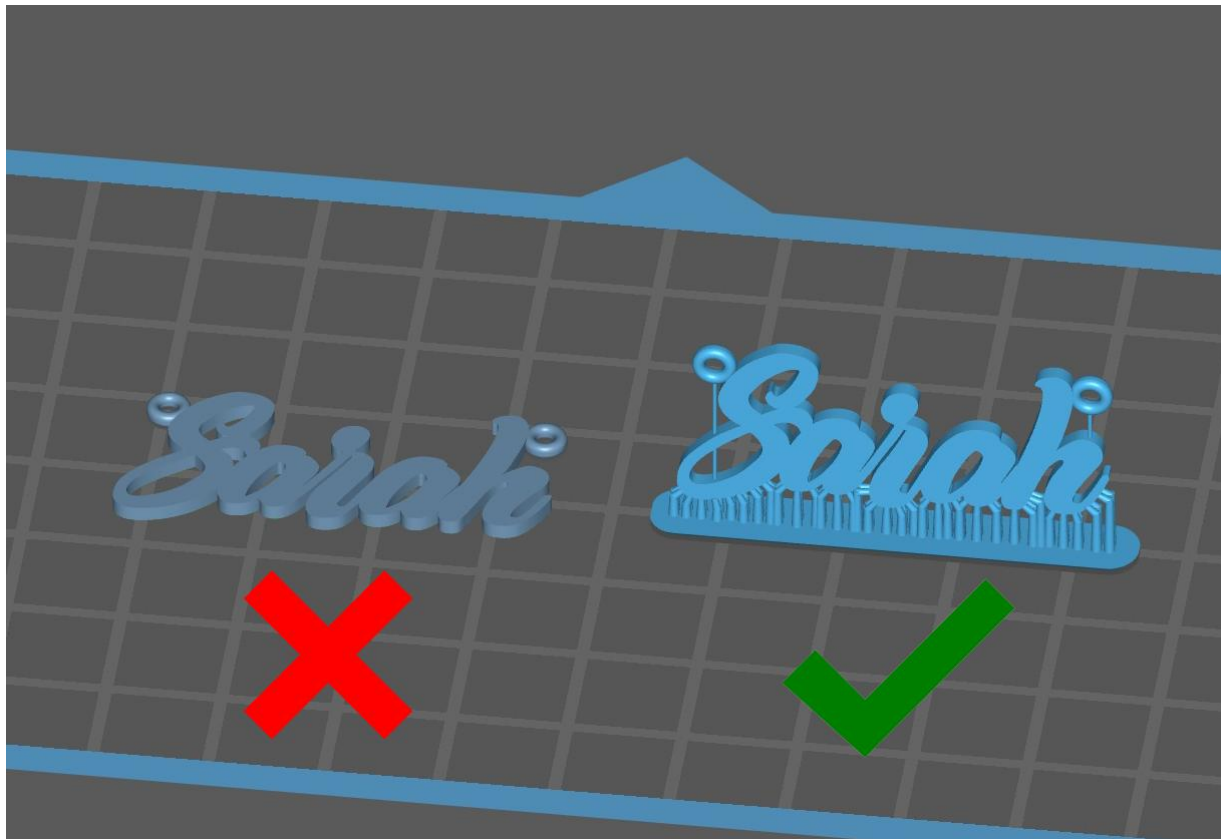

Supports

Make sure you are using medium to thick supports

Image 1.3, 1.4, 1.5 show the do's and don't on how to add supports to the base of the ring.

We recommend using 0.6mm tip and 1.5mm base (As shown in the photo below)

Img 1.2

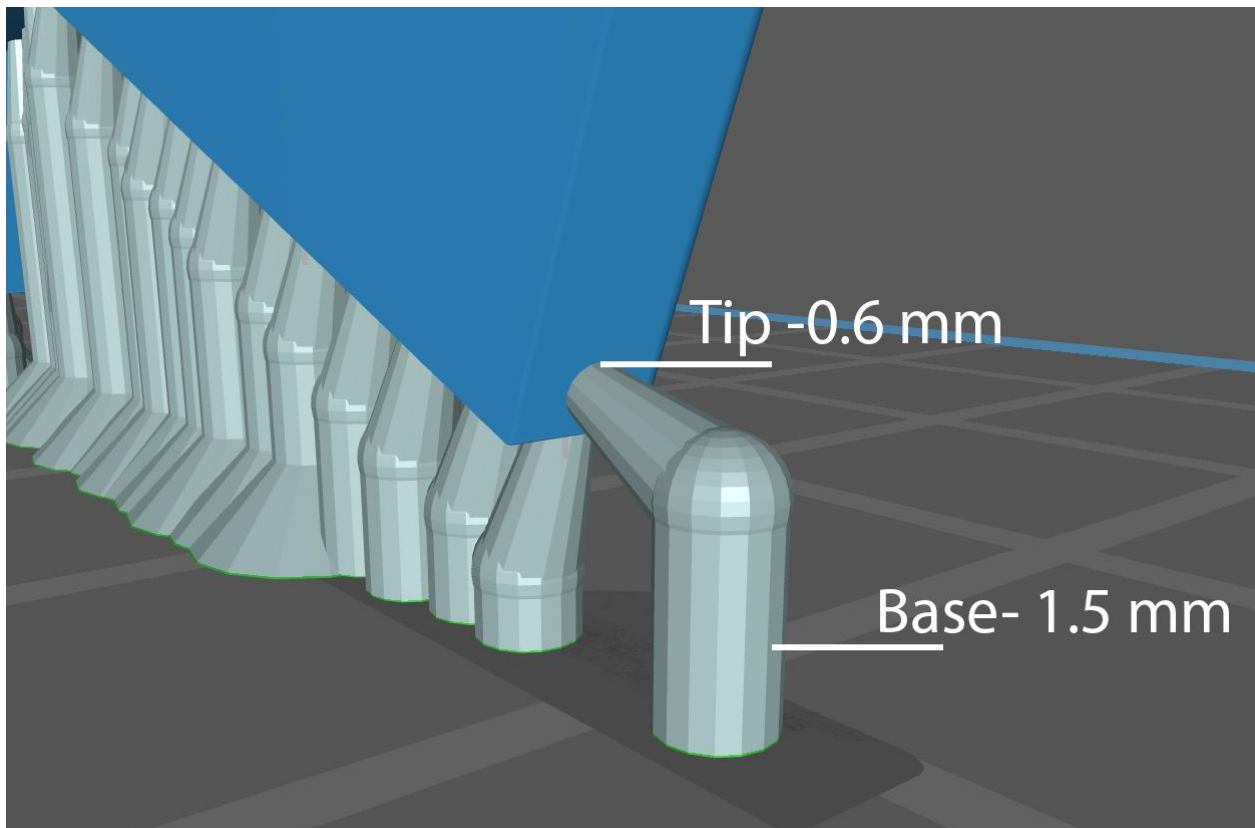

Img 1.3

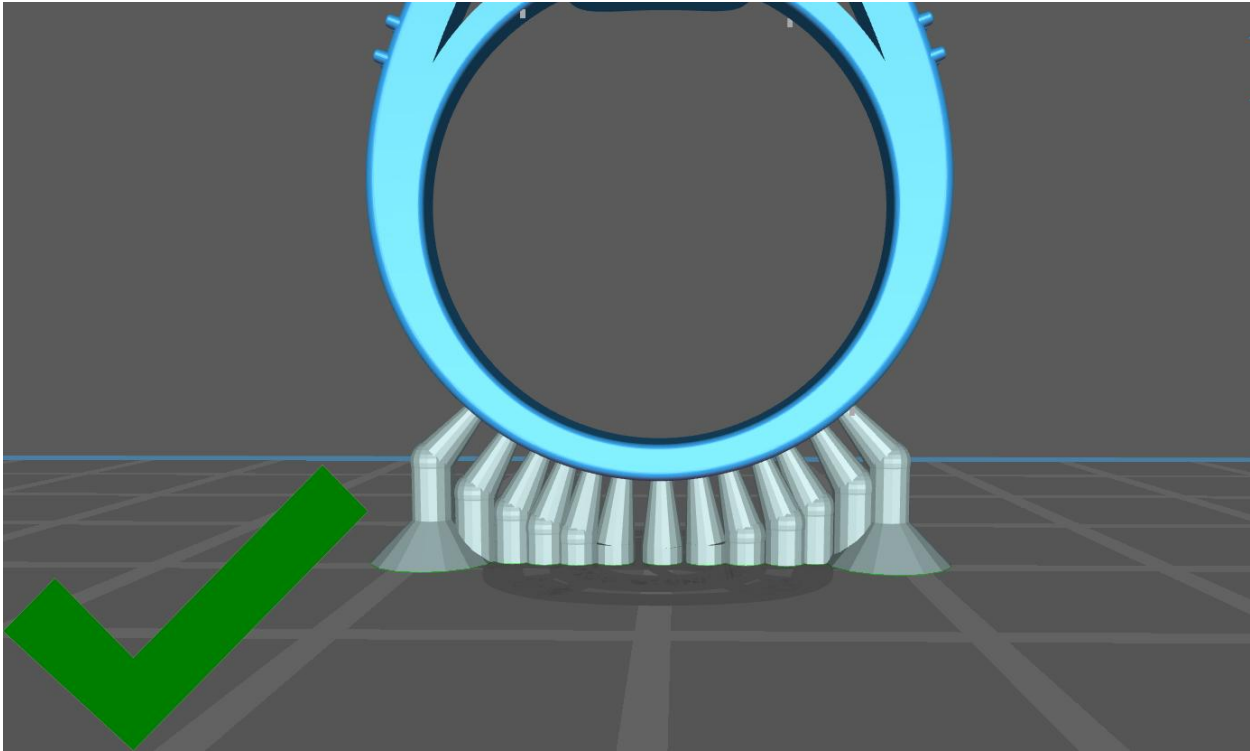

Img 1.4

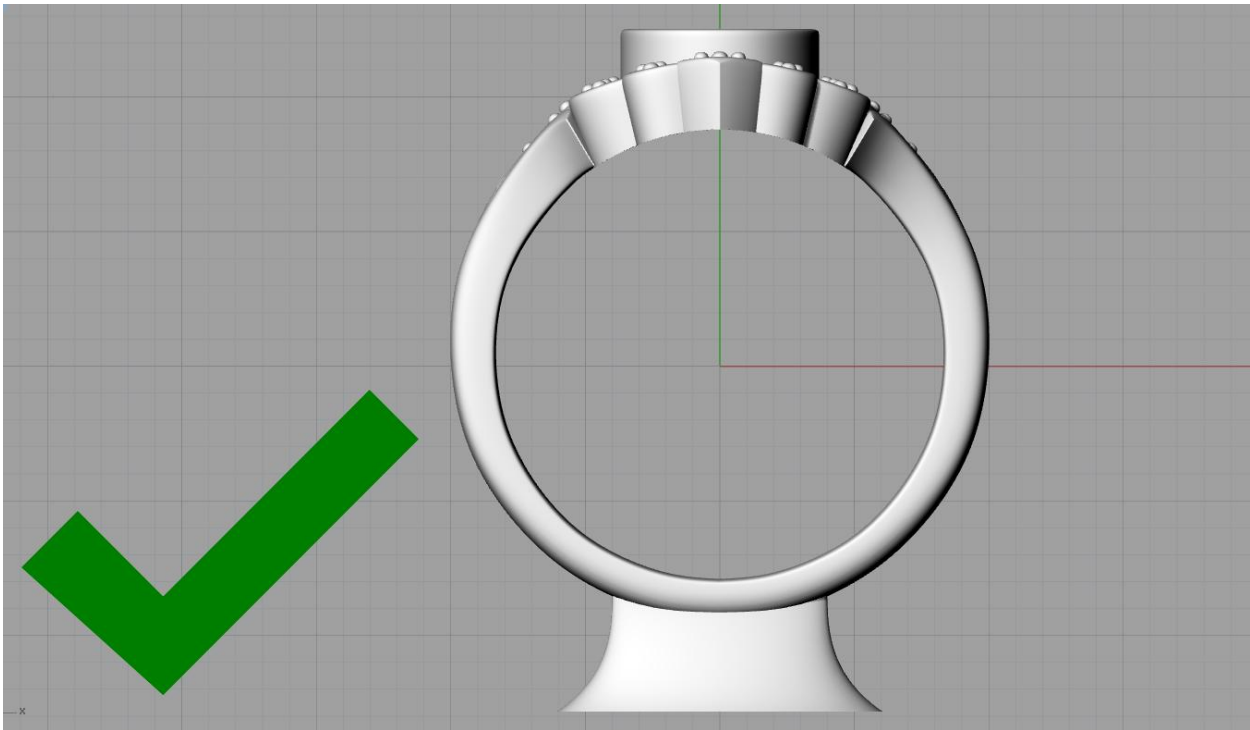

Img 1.5

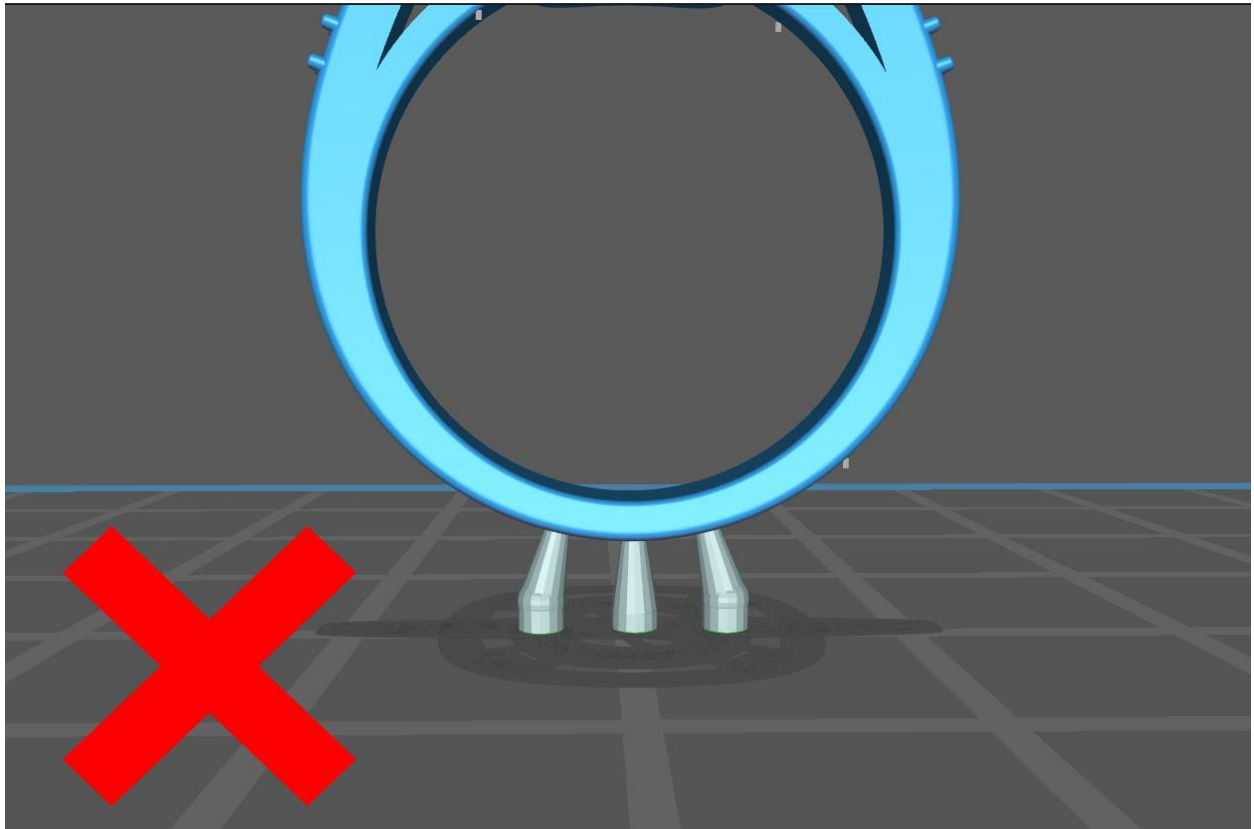

Minimal supports as the image above are not efficient for our wax line of resins.